

-PARTICOLARE / DETAIL B-

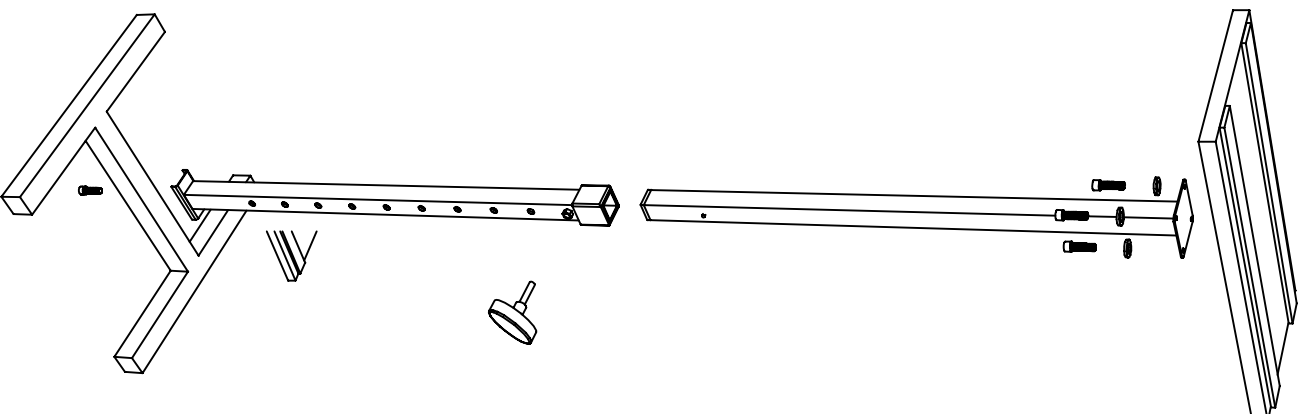
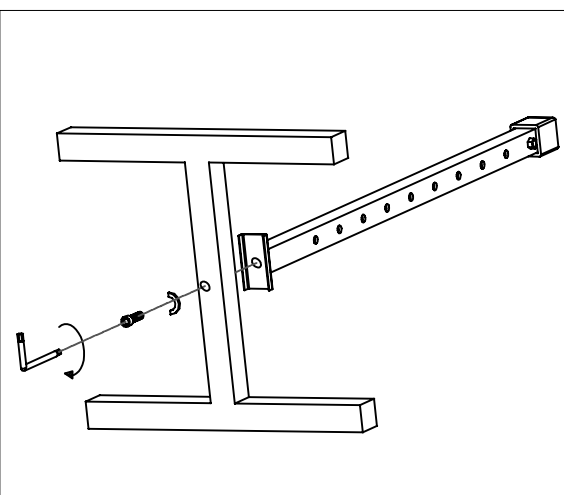

FASI DI MONTAGGIO-ASSEMBLY STEPS

- 1- MONTARE IL PIANO SUL TUBOLARE SCORREVOLE PER MEZZO DI 4 VITI E RISPETTIVE RONDELLE (vedi PART. A).
 - 2- FISSARE ALLA BASE IL TUBOLARE FORATO TRAMITE UNA VITE E LA RONDELLA (vedi PART. B).
 - 3- ACCOPPIARE LE DUE PARTI E INSERIRE LA MANOPOLA NEL SUO DADO (vedi PART. C).
- 1- MOUNT THE TOP PANEL ONTO THE UPRIGHT BAR WITH 4 SCREWS AND WASHERS (SEE DETAIL. A).
 - 2- FIX THE PERFORATED BAR TO THE BASE WITH A SCREWS AND WASHER (SEE DETAIL. B).
 - 3- JOIN THE TWO BARS AND INSERT THE KNOB INSIDE THE NUT (SEE DETAIL. C).

-PARTICOLARE / DETAIL C-

